

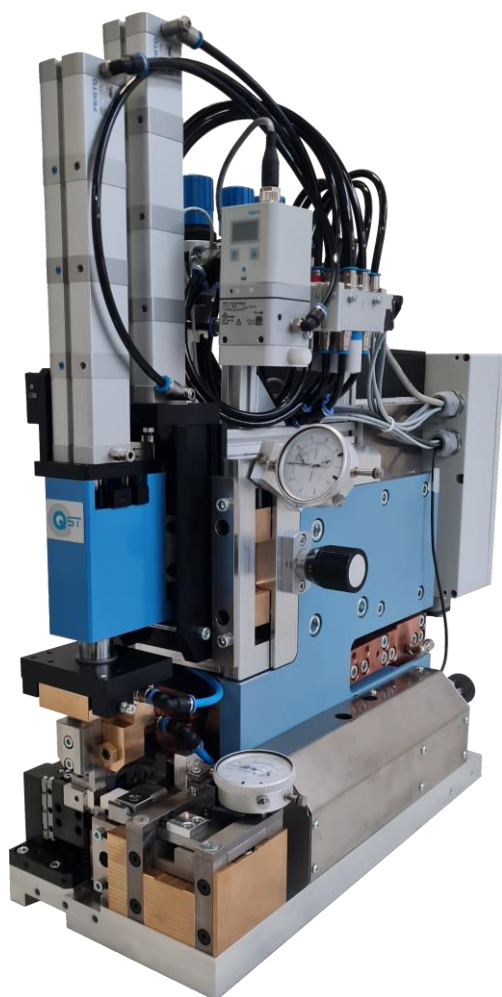

UNIVERSAL COMPACTION MODULE

KM-6



The universal compaction module to solve your compaction tasks when welding small parts.

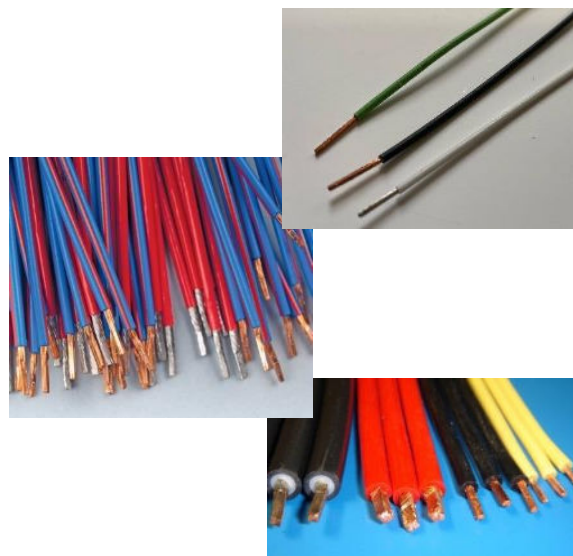

PERFORMANCE

The compacting module of the KM-6 series ensures a safe and trouble-free compacting process. The module can be used in both manual workstations and automated systems. It offers a wide range of applications in the area of small part welding.

CHARACTERISTICS

- Suitable for manual workstations and automation solutions
- Compact design
- Distance measuring system with high resolution
- Use for different cross sections
- High quality requirements
- Implementation and replacement in existing systems possible
- Quick adjustment of the desired cable cross section
... and much more

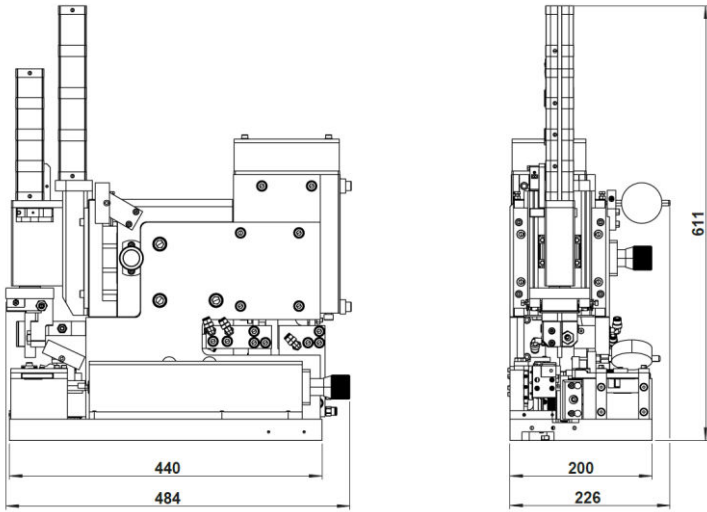

APPLICATION

- compaction welding

BENEFITS

- Effective manufacturing processes
- High flexibility
- Maximum security
- High compaction quality
- Fast integration
- Safe manufacturing processes
- Ease of maintainability

TECHNICAL DATA

Features	KM-6
In general	
Cycle time (standard pneumatic drive)	< 0,6s
Compaction width	0-3 mm infinitely adjustable
Compaction length	to 10mm
Repeatability	< +/- 0,02mm
Mechanical data	
Electrode force	approx. 100-900N
Force introduction	pneumatic
monitoring	Current, voltage, time, component recognition, gauge block, travel shutdown
Dimensions in mm	485 x 230 x 610 (L x W x D)
Weight	approx. 25 kg
Operating data	
Ambient temperature	0 – 40° C
Cooling	6 – 8 l/min
Compressed air connection	min. 6 bar network pressure
Distance measurement	5 µm

KM-6 – The universal applicable compacting module

