



MICRO PRECISION SPOT WELDING HEAD

ZFK-200



The universal spot welding heads to solve your joining and soldering task in small part welding.

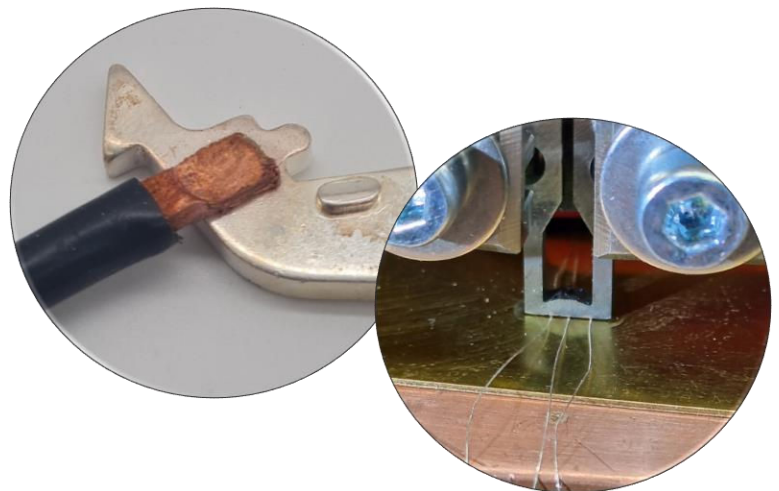

PERFORMANCE

The welding heads of the ZFK series ensures a safe and trouble-free welding process. The flexible systems can be used in both manual workstations and automated systems. The heads offer a wide range of applications in the area of small part welding

CHARACTERISTICS

- Suitable for manual workstations and automation solutions
- Compact design
- Use with weld materials with good or poor weldability
- Integrated distance measuring system
- High quality requirements
- Implementation and replacement in existing systems possible
- Quick replacement of the power-springs/follow up units
- numerous applications
- Pneumatic or servo-electric version averable
- ... and much more

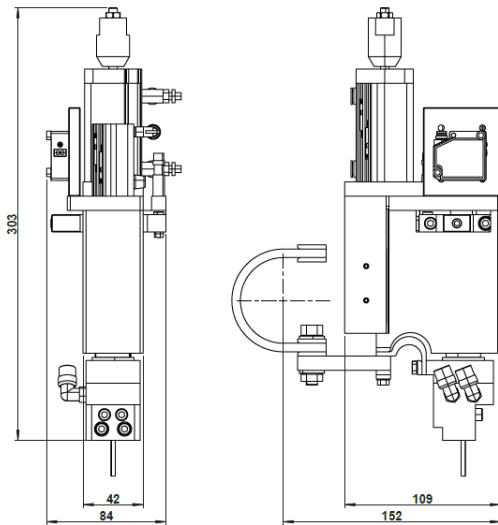

APPLICATION

- Spot welding
- Projection welding
- Contact welding
- Resistance soldering

BENEFITS

- Effective manufacturing processes
- High flexibility
- Maximum security
- High weld quality
- Fast integration
- Safe manufacturing processes
- Ease of maintainability
- High cycle times
- Gentle landing



ZFK – 200

The universal spot welding heads to solve your joining and soldering task in small part welding

TECHNICAL DATA

Features	ZFK-200
In general	
Style	Guide head for integration without rack
Options	Customer-specific adaptation to the welding task
Electrical data	
Secondary connection	Secondary cable to the transformer 70 mm ² – 90 mm ²
Signaler	Proximity initiator type PNP (force / pressure reached) Distance sensor sinking distance - laser distance sensor type OM20 - P0120.HH.YUN from Baumer
Maximum welding current	approx. 8 kA at 50% E.D.
Mechanical data	
Welding force	approx. 15 N – 175 N depending on the power cylinder
Force introduction (actuation)	pneumatic
Force adjustment	pneumatic
Compressed air connection	max. 6 bar
Electrode holding	Electrodes \varnothing 3 mm
Arm projection / Arm distance	Adaptation to the welding task
Electrode stroke in mm	0 – 30
Dimensions in mm	328 x 95 x 109 (H x W x D)
Weight	approx. 4 kg
Operating data	
Ambient temperature	0 – 40° C
Cooling	Water-cooled electrode arm holders