

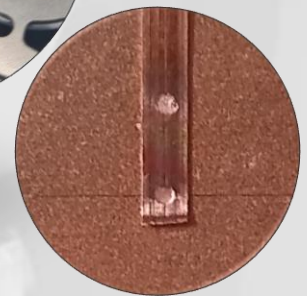

DSKF-600

The universal spot welding heads to solve your joining and soldering task in small part welding



PERFORMANCE

The SKF series welding heads guarantee you a safe and trouble-free welding process. The flexible systems can be used in both manual workstations and automated systems. The heads offer a wide range of applications in the area of small part welding.



CHARACTERISTICS

- Suitable for manual workstations and automation solutions
- Use with weld materials with good or poor weldability
- Compact design
- Distance measuring system can be easily upgraded
- Quick replacement of the power-springs/follow up units
- High quality requirements
- Implementation and replacement in existing systems possible
- numerous applications
... and much more

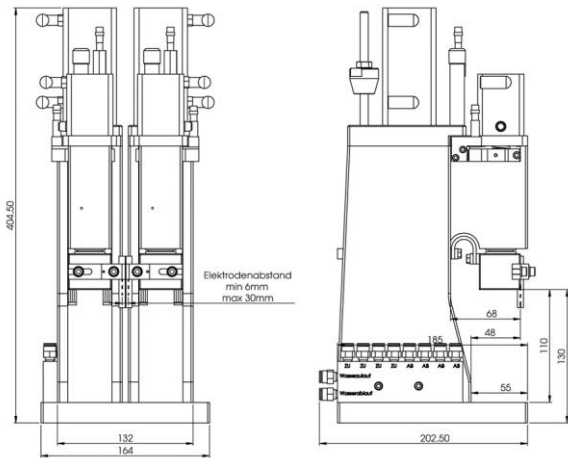

APPLICATION

- Spot welding
- Projection welding
- Cross wire welding
- Contact welding
- Resistance soldering

BENEFITS

- Effective manufacturing processes
- High flexibility
- Maximum security
- High weld quality
- Fast integration
- Safe manufacturing processes
- Ease of maintainability

TECHNICAL DATA

Features	DSKF-600
In general	
Style	Rack Version with secondary connections in double version and water distributor
Options	<ul style="list-style-type: none"> – Head for integration into machines – without rack – without lower fitting (electrode holder) – Power actuating cylinder or scale house with up to 6 different power springs
Electrical data	
Secondary connection	Secondary cable or secondary profiles to the transformer 25 mm ² – 250 mm ²
Signaler	Upper end position - proximity switch type IFRM 06P17A3/S35L PNP / Baumer head spring-loaded - proximity switch type IFRM 08P17A3/S35L PNP / Baumer
Maximum welding current	approx. 16 kA at 50% E.D.
Mechanical data	
Welding force	approx. 15 N – 660 N depending on the power cylinder
Force introduction (actuation)	pneumatic
Force adjustment	manually with scale house and knurled screw or pneumatically with power cylinder
Compressed air connection	min. 6 bar to max. 7 bar network pressure
Electrode holding	Electrodes \varnothing 6 mm
Arm projection / Arm distance	max. approx. 100 mm / approx. 75 mm, mechanically adjustable
Electrode stroke in mm	0 – 60, mechanically adjustable
Dimensions in mm	404,5 x 164 x 202,5 (H x W x D)
Weight	approx. 10 kg
Operating data	
Ambient temperature	0 – 40° C
Cooling	Water-cooled electrode arm holders, electrode arms optional