

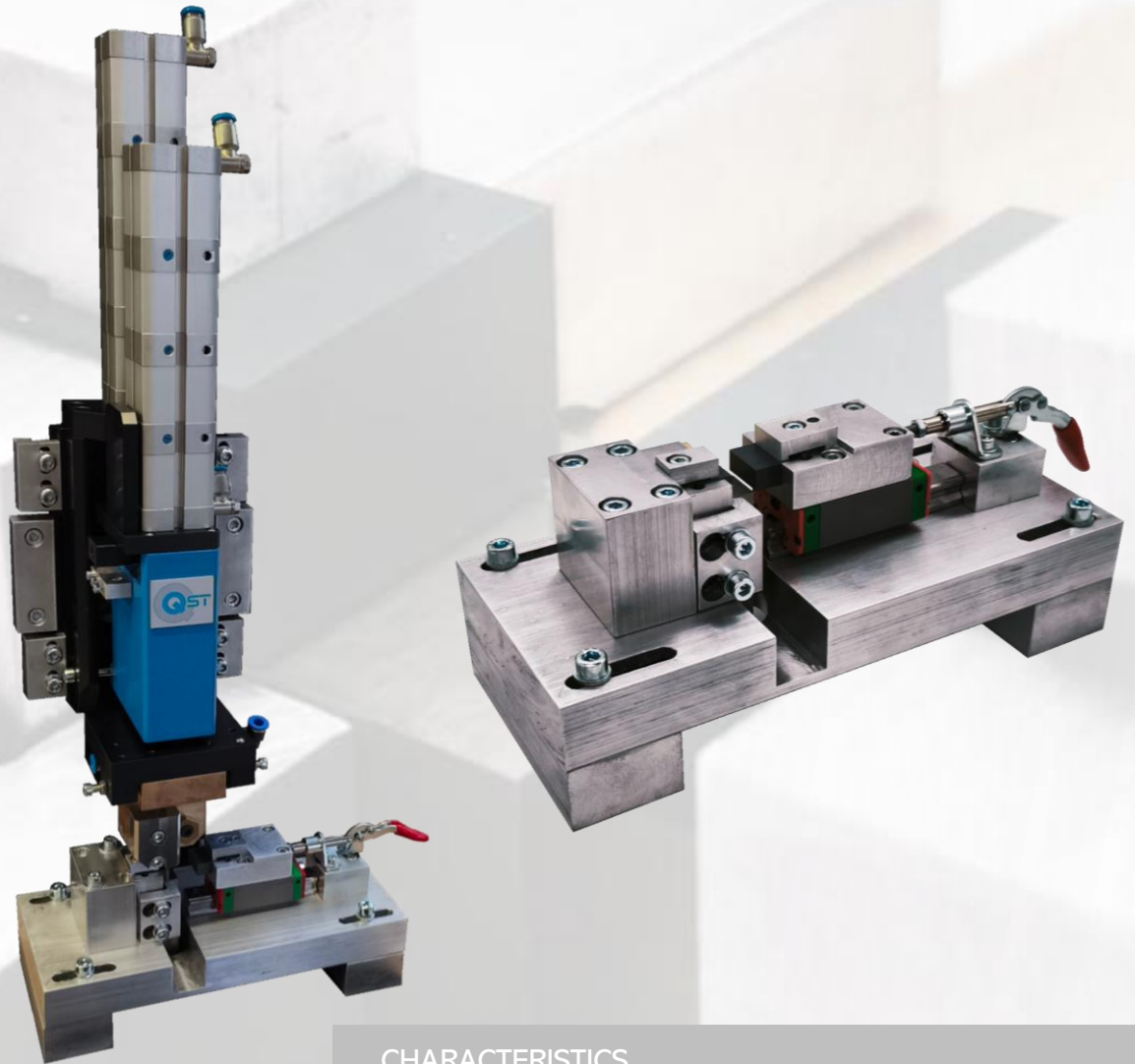

KE-1

The universal compaction module to solve your compaction tasks when welding small parts.



PERFORMANCE

The compacting unit of the KE-1 series ensures a safe and trouble-free compacting process. The unit is designed for manual workstations. Thanks to its simple construction, it provides a reliable compacting system for maximum quality at an unbeatable price.

CHARACTERISTICS

- Suitable for manual workstations
- Compact design
- Suitable for different cross-sections by using different electrode shafts
- High quality requirements
- Can be implemented and exchanged in existing manual systems

... und vieles mehr

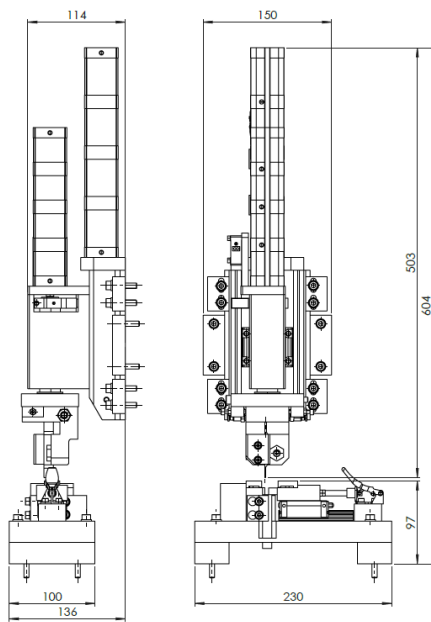

APPLICATION

- compaction welding

BENEFITS

- Effective manufacturing processes
- High flexibility
- Maximum security
- High compaction quality
- Fast integration
- Safe manufacturing processes
- Ease of maintainability

TECHNICAL DATA

Features	KE-1
In general	
Cycle time (standard pneumatic drive)	Manual operation
Compaction width	On request
Compaction length	to 10mm
Repeatability	< +/- 0,1 mm
Mechanical data	
Electrode force	approx. 100 N – 900 N
Force introduction	pneumatic
Compressed air connection	max. 6 bar
Distance measurement	5 µm
monitoring	Current, voltage, time, component detection, final dimension, travel cut-off
Dimensions in mm	approx 140 x 230 x 605 (L x W x D)
Weight	approx. 5 kg
Operating data	
Ambient temperature	0 – 40° C
Cooling	6 – 8 l/min

